

Ersa ECOSELECT 4

Inline and batch selective soldering system
for highest selective soldering quality



Ersa ECOSELECT 4

Inline and batch selective soldering system for highest selective soldering quality



Highlights ECOSELECT 4

- Flexibly integrable soldering system: inline or batch operation
- VERSAFLOW 4 technology
- PCB size 508 x 508 mm
- Roller conveyor
- Up to two spray heads and flux tanks
- Power convection
- Y/Z variable dual solder pots
- Automatic nozzle activation
- Upgrade with independent flux module to a full inline machine
- Award-winning ERSASOFT 5 software
- VERSACAM – solder wave height measurement “on the fly”

The **ECOSELECT 4** is Ersa's newest selective soldering system. It is a compact system that is perfectly suited for small up to medium-sized batches where flexibility is essential.

The **ECOSELECT 4** features machine technology of the latest **VERSAFLOW** generation. Its conveyor system is a high-quality roller conveyor for a max. PCB size of 508 x 508 mm. The **ECOSELECT 4** can be used inline or in batch operation. Another machine highlight is the new power convection heating, for example, which provides an optimal and homogenous warm-up also of complex boards. Like all Ersa selective soldering systems the **ECOSELECT 4** is equipped

with a programmable precision spray fluxer with integrated spray control for precise and economical flux application in single spots or in tracks. A second spray head is available as an option.

The new dual solder pot system of the **VERSAFLOW 4** is also available for the **ECOSELECT 4**. Both Miniwave pots can be moved flexibly in Y/Z direction. Thus, the machine operator can install solder nozzles with different diameters in order to quickly solder connectors using a nozzle with large diameter and using a very slim nozzle shape for joints which are difficult to reach.



Soldering system for inline or batch operation



Roller conveyor



Basic configuration

- 3 axis positioning system
- Max. PCB size 508 x 508 mm
- Solder module with low-maintenance electromagnetic solder pump
- Exhaust control
- Status indication lights
- Process visualization incl. soldering protocols, process data recording, monitoring function, indication of maintenance and errors
- Roller conveyor
- Conveyor width adjustment
- Infeed/outfeed module
- High-precision spray fluxer
- Lead-free single point solder module with solder level monitoring and wave height measurement

The innovative and user-friendly **ERSASOFT 5** software renders machine operation even more intuitive. Through individual user interfaces, each group of operators receives, at one glance, the data and information it requires. A further software highlight is the PiP technology (picture in picture) combined with a process monitoring camera.



Power convection heating



Y/Z variable dual solder pots



Automatic nozzle activation

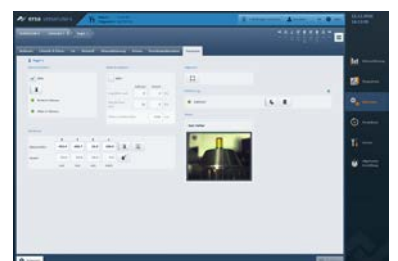

ERSASOFT 5

Technical data ECOSELECT 4

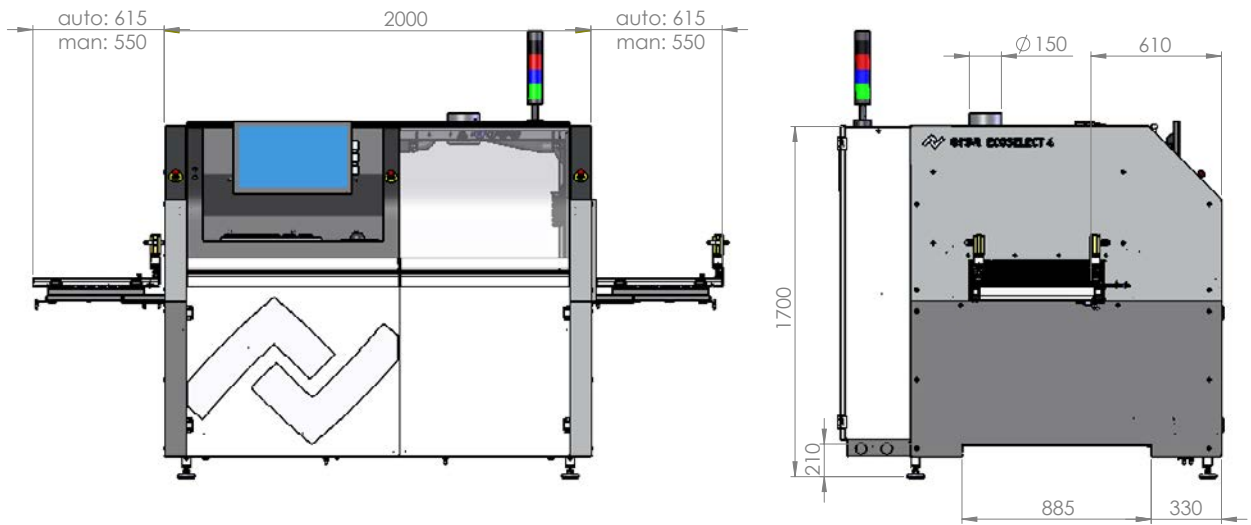

ECOSELECT 4 (basic system)

Length:	2,000 mm
Width:	1,800 mm
Height:	1,700 mm
Weight:	1,200 kg
Type:	batch/inline
PCB loading:	manual/automatic

Conveyor system

Type:	roller conveyor
PCB width:	50 – 508 mm (single track)
PCB length:	127 – 508 mm
Clearance from PCB edge:	3 mm
PCB top side clearance:	max. 120 mm
PCB bottom side clearance:	max. 60 mm
Speed:	0.2 – 15 m/min
Mask/PCB weight:	15 kg (heavy load conveyor optional)

Flux module

Type:	high-precision spray fluxer
Positioning system:	2 axis, servo motor driven
Flux storage tank:	1,8 l
Positioning speed:	1 – 400 mm/s
Fluxer speed:	20 mm/s
Positioning accuracy:	±0,15 mm
Spray width:	2 – 8 mm (130 µm nozzle)

Preheat module

Type:	IR bottom-side (basis), top-side convection (option), top side power convection (option)
Power:	12 kW per IR heater, 5 kW (convection), 6 kW (power convection)
Temperature:	200 °C

Miniwave solder module

Solder wave height:	max. 5 mm
Clearance from PCB edge:	min. 3 mm
Solder volume:	approx. 13 kg (Sn63Pb) approx. 12 kg (lead-free)
Solder temperature:	max. 330 °C
Warm-up time:	75 min to 280 °C
Positioning speed:	X/Y; 2 – 200 mm/s
Soldering speed:	10 mm/s
Positioning accuracy:	±0,15 mm

Nitrogen technology

Nitrogen supply:	to be supplied locally
Nitrogen injection:	N ₂ cover over the solder bath
Required pressure:	6 bar
Consumption:	approx. 1.5 m ³ /h per pot
Particle cleanliness:	5.0 (recommendation)

Compressed air

Compressed air supply:	to be supplied locally
Required pressure:	6 bar
Consumption :	< 5 m ³ /h

Electrical data

Power:	5-wire system, 3 x 230/400 V, N, PE
Power tolerance range:	±5 %
Frequency:	50/60 Hz
Power consumption:	22 kW (incl. bottom side preheating)
Safety fuse:	3 x 35 A

Exhaust rating

Exhaust stacks:	1 pc., OD 150 mm
Exhaust volume per stack:	350 m ³ /h

Environmental specs/noise level

Ambient temperature:	15 – 35 °C
Permanent sound level:	<60 dB(A)

Ersa GmbH
Leonhard-Karl-Str. 24
97877 Wertheim/Germany

Phone +49 9342 800-0
Fax +49 9342 800-127
info@ersa.de
www.ersa.com

 **kurtz ersa**