

# Ersa ECOSELECT 1

Small dimensions – outstanding technology



# Ersa ECOSELECT 1

## Selective soldering for small and special series



Dynamic preheating concept with top- and bottom-side heating



Solder module with two solder baths on the same axis

### Basic Configuration

- 3-axes positioning system
- Universal carrier for PCB's
- Precision spray fluxer
- Solder module with electromagnetic solder pump
- Exhaust air monitoring
- Operation status indication
- Process visualization including solder protocols, process data writer, monitoring function, maintenance and error message indication

### Highlights ECOSELECT 1

- Compact Batch-type system with small footprint
- Up to 2 solder bath to increase throughput
- Lower, full-area IR preheater (scalable)
- Convection top side
- Processing of max. board sizes of 508 x 508 mm

Requiring less than 3 m<sup>2</sup> of space the ECOSELECT 1 fits optimally into cell production environments. Nevertheless, the small semiautomatic ECOSELECT 1 uses the same successful and proven Ersa selective soldering technology as the large VERSAFLOW systems. This means: No compromises at all in quality and accuracy.

The fluxer provides highest positioning accuracy consuming lowest amounts of flux. Numerous control features such as spray monitoring or continuous pressure monitoring of the flux storage tank provide for the outstanding Ersa Process Safety. The full-area preheating system features bottom-side IR heaters that can be switched in groups and topside convection. It

provides for efficient, homogenous and reproducible heating of the assemblies, also with demanding applications such as multi-layers or heavy-mass.

Just like in the VERSAFLOW systems the ECOSELECT 1 solder module is equipped with a lowest-maintenance solder pot with electromagnetic solder pump. Advantages: very constant flow rates and precise adjustment of the solder wave height.

Dynamic process parameters like solder level, solder wave height and solder temperature are continuously monitored and documented. Thanks to the innovative „Peel OFF“ Feature bridging is not an issue, even when soldering on a horizontal conveyor.

Due to the innovative dual solder pot, two different solder alloys can be processed. Consequently high machine downtimes for the solder pot exchange are history. Alternatively this system can also be operated with solder nozzles having different diameters.

Operation and control of the ECOSELECT 1 is effected with the innovative and user-friendly ERSASOFT machine software. An integrated process recorder and the solder protocol guarantee traceability according to ZVEI standards. By means of the CAD Assistant solder programs can be created quickly and easily using CAD files or image files of scanned PCBs. The solder program created in this way can then immediately be used in the ECOSELECT 1.



Convenient manual infeed + barcode scanner for automatic product identification

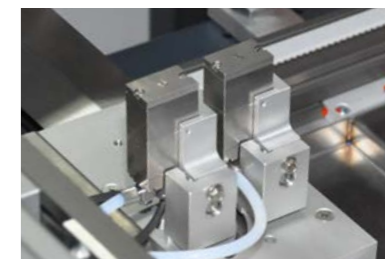

Precision spray fluxer with up to 2 flux heads



Maximum board size 508 x 508 mm

# Technical data ECOSELECT 1

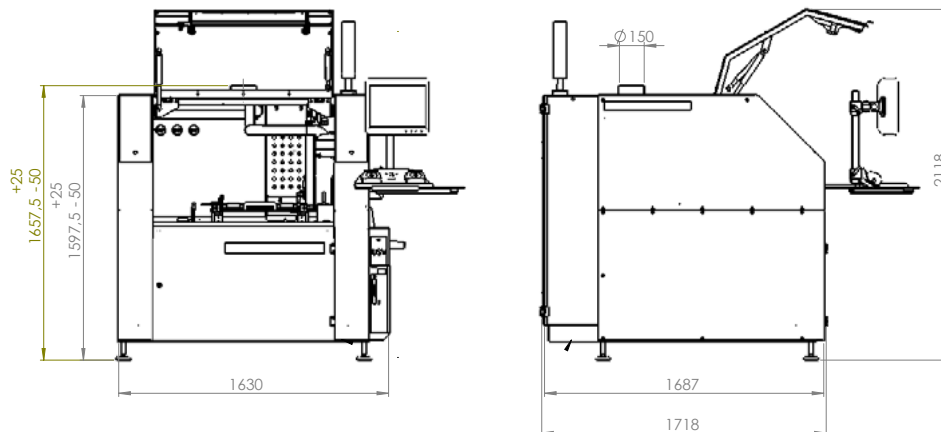

Specifications refer to the basic machine and may vary depending on the configuration.

ECOSELECT 1 (basic system)	
Length:	1.700 mm
Width:	1.500 mm
Height:	1.612 mm
Weight:	approx. 900 kg
Type:	batch
PCB loading:	manuel

Conveyor system:	
Universal-Maskenaufnahme	
PCB width:	15 – 508 mm
PCB length:	15 – 406 mm (optional 508 mm)
Clearance from PCB edge:	3 mm
PCB top side clearance:	max. 120 mm
PCB bottom side clearance:	max. 30 mm
Mask/PCB weight:	8 kg

Exhaust rating	
Exhaust stacks:	1 pc., OD 150 mm
Exhaust volume per stack:	200 m <sup>3</sup> /h

Flux module	
Type:	high-precision spray fluxer
Positioning system:	2 axis, servo motor driven
Flux storage tank:	1,8 l
Positioning speed:	1 - 300 mm/s
Fluxer speed:	20 mm/s
Positioning accuracy:	±0,25 mm
Spray width:	2 - 8 mm (127 µm nozzle)

Preheat module	
Type:	IR bottom-side (basis), top-side convection (option)
Power:	10,4 kW per IR heater, 4 kW convection
Temperature:	200 °C

Compressed air & Nitrogen	
Compressed air supply:	to be supplied locally
Required pressure:	6 bar
Consumption:	< 5 m <sup>3</sup> /h
Nitrogen Consumption:	approx. 1.5 m <sup>3</sup> /h
Particle cleanliness: (recommendation)	5.0

Solder module:	
Solder wave height:	max. 5 mm
Clearance from PCB edge:	min. 3 mm
Solder volume:	approx. 13 kg (Sn63Pb37); approx. 12 kg (lead-free)
Solder temperature:	max. 330 °C
Warm-up time:	75 min bis 280 °C
Positioning speed:	x/y: 2 – 200 mm/s
Soldering speed:	10 mm/s
Positioning accuracy:	±0,25 mm

Electrical data	
Spannung:	5-wire system, 3 x 230/400 V, N, PE
Power tolerance range:	±10 %
Frequency:	50/60 Hz
Power consumption:	19 kW (incl. bottom side preheating)
Safety fuse:	3 x 35 A

Environmental specs/noise level	
Ambient temperature:	15 – 35 °C
Permanent sound level:	<60 dB(A)

**America**  
Kurtz Ers, Inc.  
usa@kurtzersa.com

**Mexico**  
Kurtz Ers México, S.A. de C.V.  
info-kmx@kurtzersa.com

**Asia**  
Kurtz Ers Asia Ltd.  
asia@kurtzersa.com

**China**  
Ersa Shanghai  
info-esh@kurtzersa.com

**Vietnam**  
Kurtz Ers Vietnam Company Limited  
info-kev@kurtzersa.com

**France**  
Ersa France  
info-efr@kurtzersa.com