

SMARTFLOW 2020

Compact without compromises

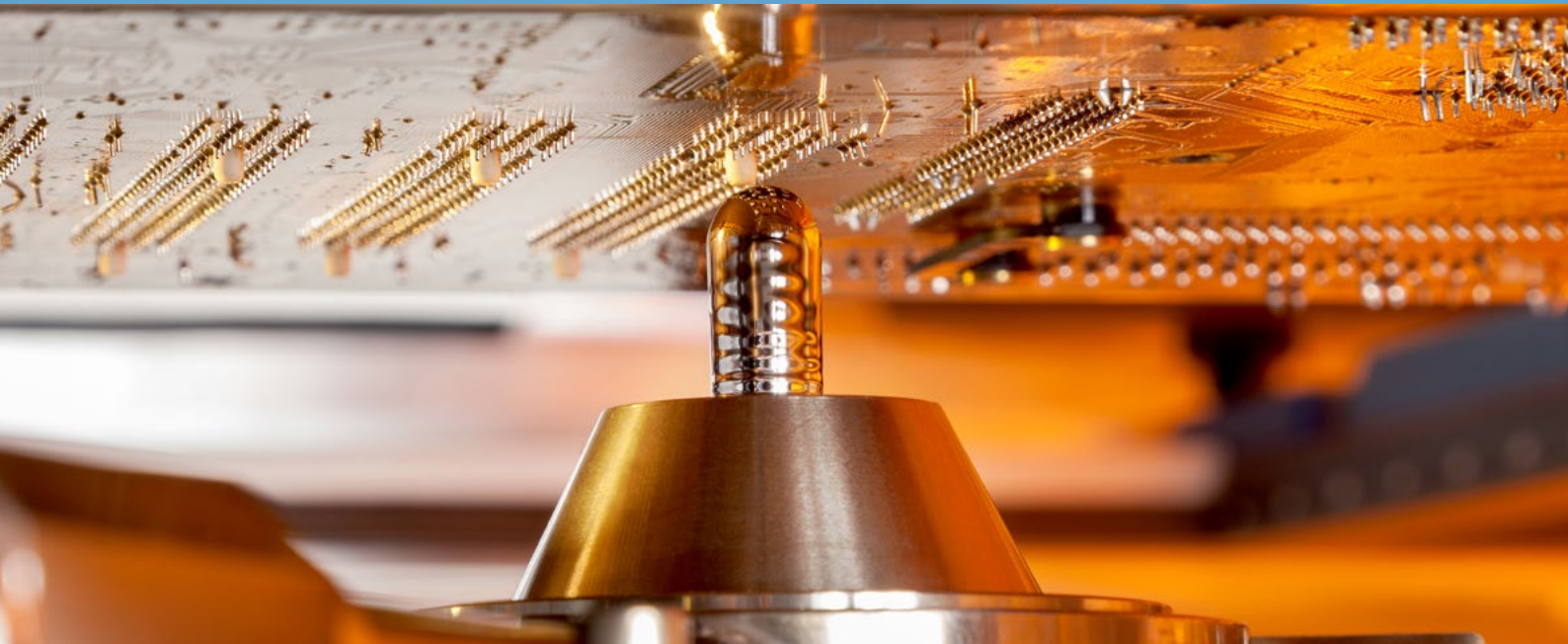

Ersa SMARTFLOW 2020

Smart technology for your electronics manufacturing

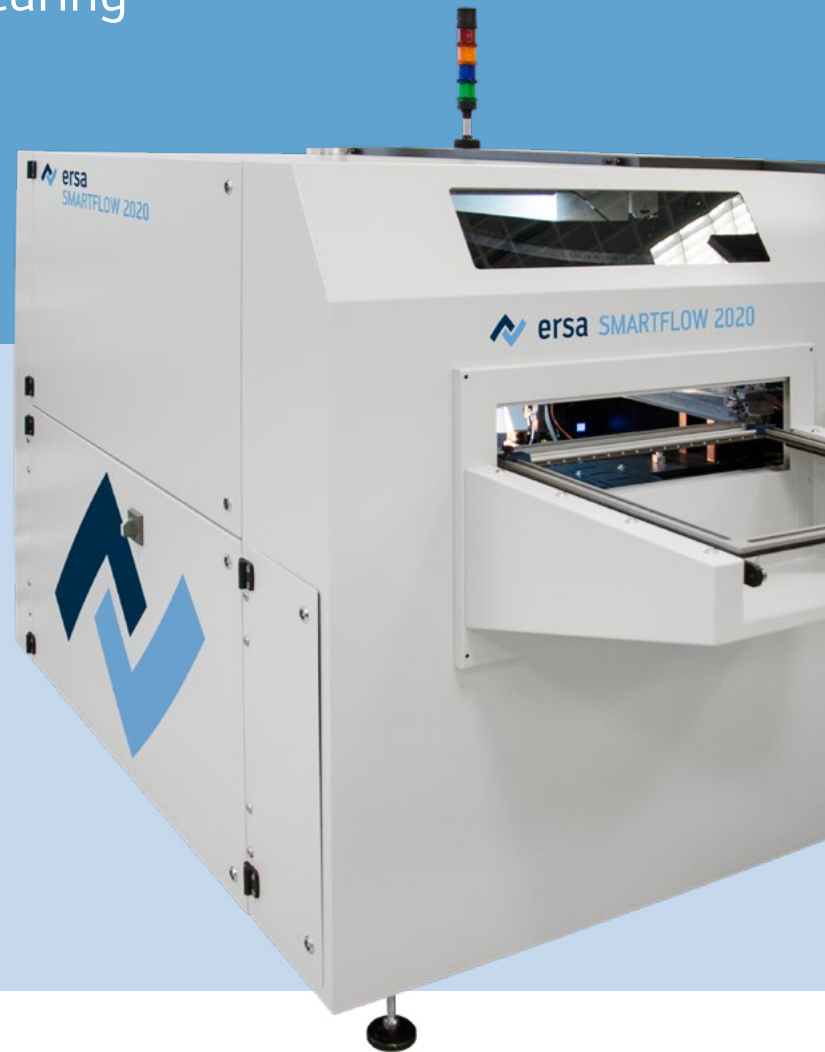

Highlights

- Perfect for manufacturing islands
- Large PCB formats
- Extremely maintenance-friendly
- Wear-free induction pump
- Full-area heating
- Modern process visualisation with ERSASOFT 5

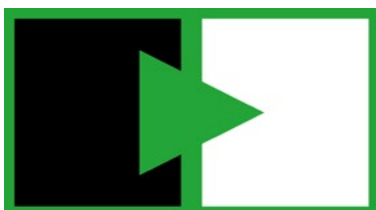

The Hermes Standard
for "M-to-M" in SMT Assembly

As a leader in selective soldering technology, Ersa has expanded its range of products in this sector by a compact selective soldering system. The SMARTFLOW has a smaller footprint than the bigger VERSAFLOW systems. This batch system impresses with state-of-the-art technology and easy operability.

The SMARTFLOW manages with an area barely more than what would be required for a modern hand soldering work station. It is thus perfect as an entry-level system or for smaller productions. PCB sizes of 20 x 20" (508 x 508 mm) can easily be processed with the SMARTFLOW. Going by the "Compact without compromises" motto, you do not need to dispense with anything with this system. Just like all Ersa selective systems, this machine is equipped with the low-maintenance

and wear-free solder pot with induction pump and has a full-area preheating, which can be segmented depending on the heat requirement and assembly size. The reliable Ersa high-precision spray flux system is also used here.

SMARTFLOW is equipped with modern ERSASOFT 5 operating software. This new version of our time-tested machine software impresses with its user-oriented structure in addition to modern visualisation. Thanks to individual user interfaces, every user group obtains the required data and information at a glance. The new interface is also convenient when it comes to process monitoring. Thanks to modern PiP technology (picture-in-picture), soldering parameters and a live process picture are available at a glance, for optimum control during every single soldering



High single solder nozzle with a narrow diameter – ideal for solder joints between high components



MINI-VARIO-WAVE solder nozzle for optimized throughput



Simple Selective Soldering – Plug'n'Play



Basic configuration

- 3-axis positionig system
- Work piece carrier for a max. PCB size of 508 x 508 mm
- High-precision spray fluxer
- Solder module with low-maintenance electromagnetic solder pump
- User-friendly PC control with touch screen
- ERSASOFT 5 operating software
- Exhaust monitoring
- Status indication light
- Process visualization including solder protocol, process data writer, monitoring function, maintenance and error message indication, password protection

process. This system is also surprisingly smart during maintenance work. Thanks to the doors that can be opened widely, all the work can be carried out from one side of the machine. This reduces the required expenditure of time significantly and thus increases the machine availability.

The installation of the machine is just as simple as the servicing. It is ready for use in almost no time after connecting it to the current, compressed air and nitrogen supply. Easy installation, servicing and operability make SMART-FLOW the perfect compact selective soldering system, which also impresses selective soldering professionals with its uncompromising technology.

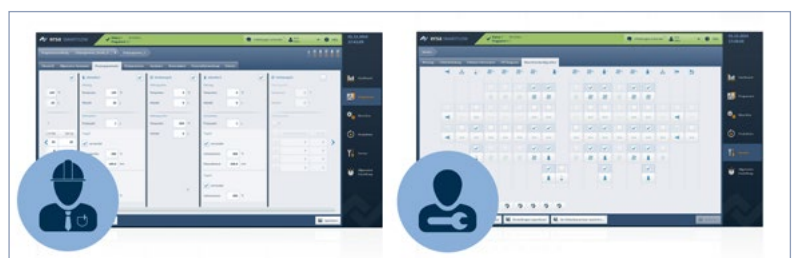

ERSASOFT 5 with user-oriented menu navigation and PiP function for optimum overview

Technical data SMARTFLOW 2020

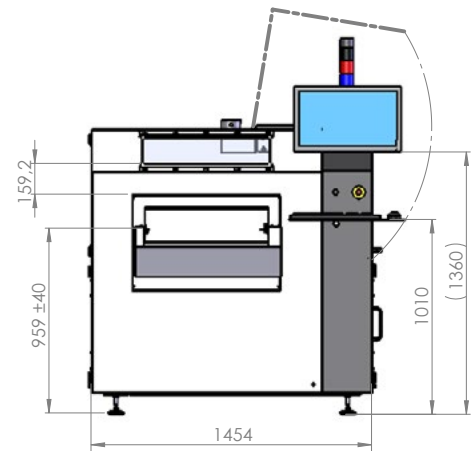
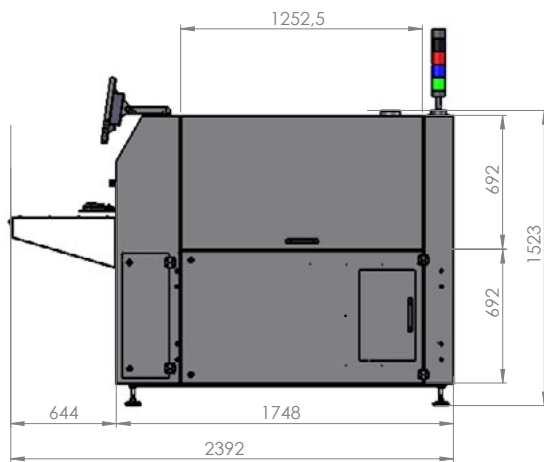

SMARTFLOW (basic system)	
Length:	1,750 mm
Width:	1,450 mm
Height:	1,520 mm
Weight:	1,000 kg
Type:	batch
PCB loading:	manual

Electrical data	
Power:	5-wire system, 3 x 230/400 V, N, PE
Power tolerance range:	±10 %
Frequency:	50/60 Hz
Power consumption:	22 kW
Safety fuse:	max. 33.5 A

Transport	
Type:	universal work piece carrier
PCB width:	15 – 508 mm
PCB length:	15 – 508 mm
Clearance from PCB edge:	3 mm
PCB top side clearance:	max. 80 mm
PCB bottom side clearance:	max. 60 mm
Mask/PCB weight:	3 kg

Flux module	
Type:	high-precision spray fluxer
Positioning system:	separate X/Y axis with step motor
Flux storage tank:	1,8 l
Positioning speed:	1 – 300 mm/s
Fluxer speed:	20 mm/s
Positioning accuracy:	±0.25 mm
Spray width:	2 – 8 mm (127 µm nozzle)

Preheat module	
Type:	IR bottom-side (basis), IR top-side (option)
Power:	8 kW

Solder module Mini-wave	
Solder wave height:	max. 5 mm
Clearance from PCB edge:	min. 3 mm
Solder volume:	approx. 13 kg (Sn63Pb); approx. 12 kg (lead-free)
Solder temperature:	max. 330 °C
Warm-up time:	75 min bis 280 °C
Positioning speed:	x/y: 2 – 200 mm/s z: 2 – 100 mm/s
Soldering speed:	10 mm/s
Positioning accuracy:	±0.25 mm

Nitrogen technology	
Nitrogen supply:	to be supplied locally
Nitrogen injection:	N ₂ cover over the solder bath
Required pressure:	6 bar
Consumption:	approx. 2 m ³ /h
Particle cleanliness: (recommendation)	5.0

Exhaust rating	
Exhaust stacks:	1 pc., OD 100 mm
Exhaust volume per stack:	300 m ³ /h

Environmental specs/noise level	
Ambient temperature:	15 – 35 °C
Permanent sound level:	< 65 dB(A)

America
Kurtz Ersä, Inc.
usa@kurtzersa.com

Mexico
Kurtz Ersä México, S.A. de C.V.
info-kmx@kurtzersa.com

Asia
Kurtz Ersä Asia Ltd.
asia@kurtzersa.com

China
Ersä Shanghai
info-esh@kurtzersa.com

Vietnam
Kurtz Ersä Vietnam Company Limited
info-kev@kurtzersa.com

France
Ersä France
info-efr@kurtzersa.com

Ersä GmbH | Leonhard-Karl-Str. 24
97877 Wertheim/Germany

Tel. +49 9342 800-0
info@ersa.de | www.ersa.com

 **kurtz ersä**